

Use Existing master valve wire to add flow sensor to Rain Bird LXME using Pathway

1. Rain Bird LXME controller with flow module
2. Existing master valve with dedicated power wire and shared common
3. & 4. zone control valves
5. Nearby zone valve (may be used as a HOST valve for Pathway)



CREATIVE SENSOR TECHNOLOGY

WD-41

9/5/17

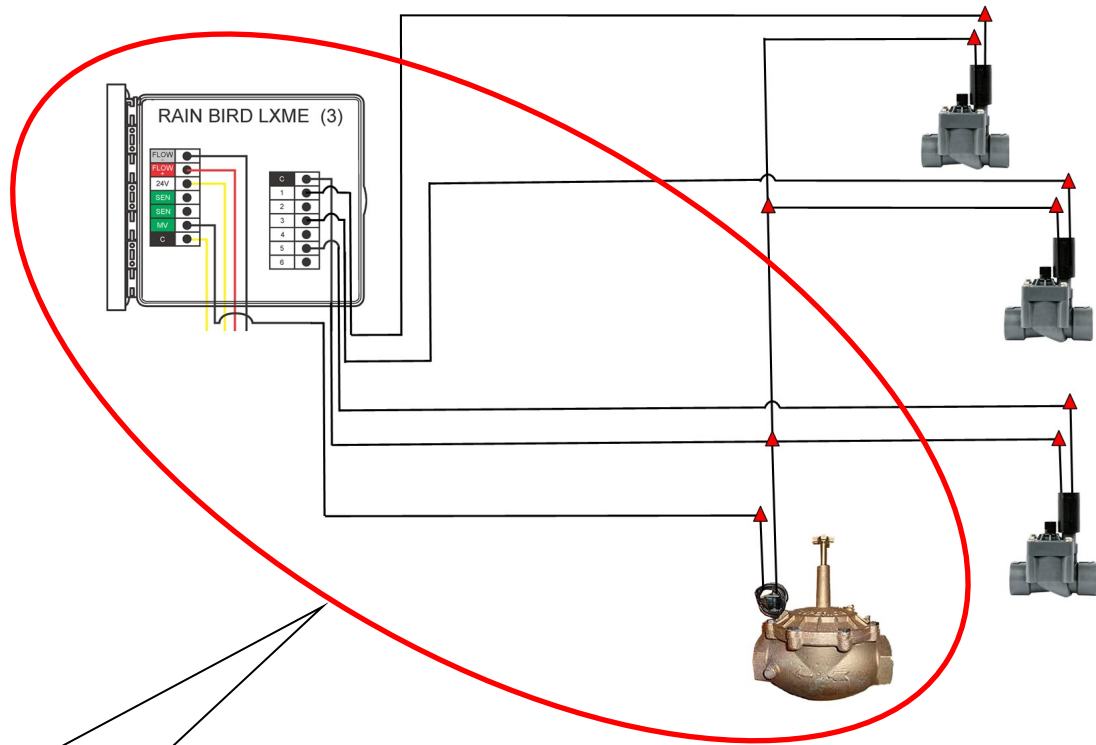

Since we have existing wire to the master valve, we will concentrate on this area only.

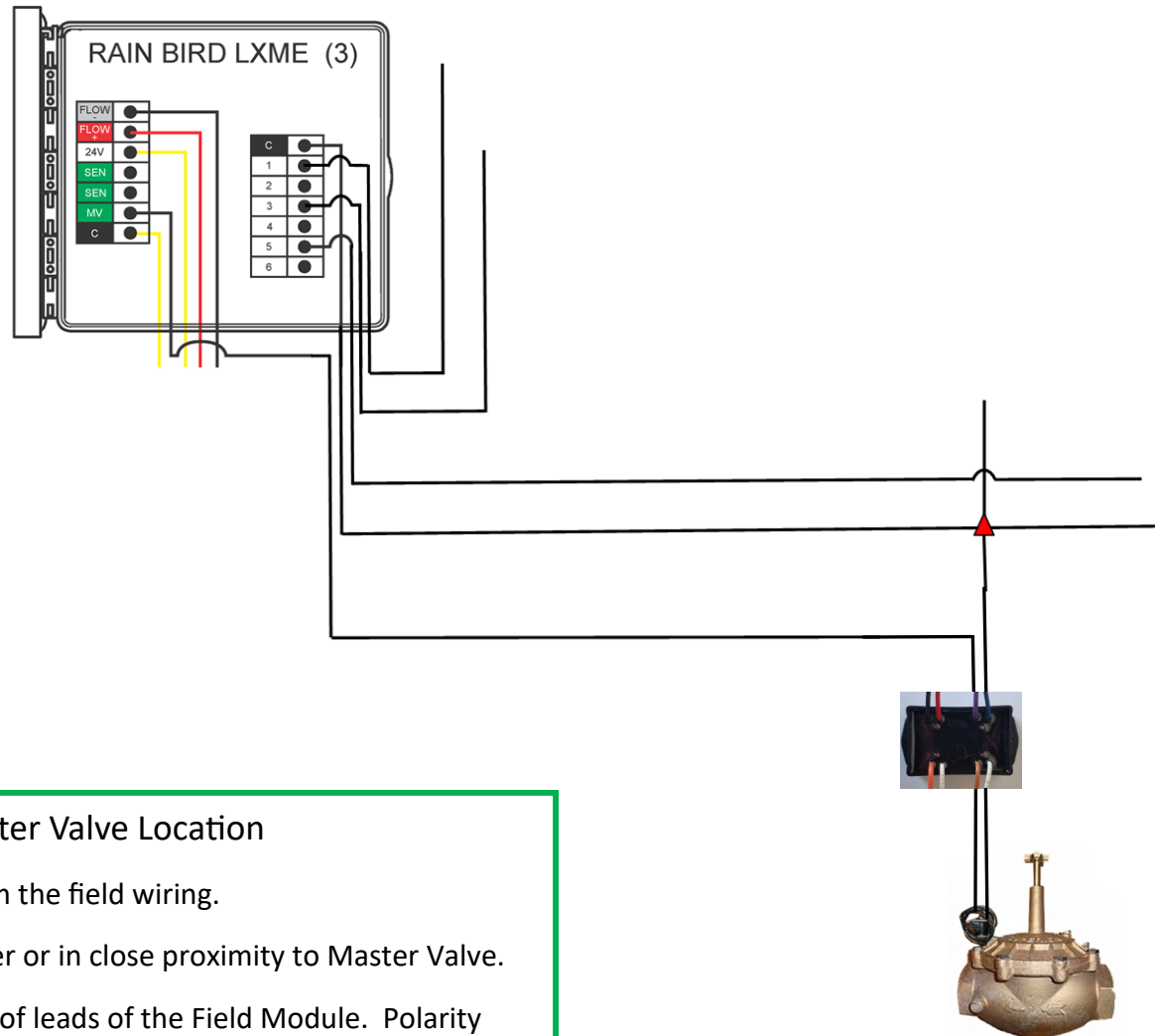

STEP 1—Start at the Master Valve Location

1. Disconnect the Master Valve solenoid lead from the field wiring.
2. Mount Pathway Field Module to valve box cover or in close proximity to Master Valve.
3. Attach solenoid leads to Brown and White pair of leads of the Field Module. Polarity does not matter.
4. Attach MV Power wire from the field to the Purple lead of the Field Module
5. Attach MV Common wire from the field to the Blue lead of the Field Module.

Note: Make all splice water tight using wire nuts and grease, gel or epoxy splice kits.

Locations are shown diagrammatically. Make sure flow sensor and master valve are properly installed in the direction of flow with proper lengths of straight pipe before and after flow sensor

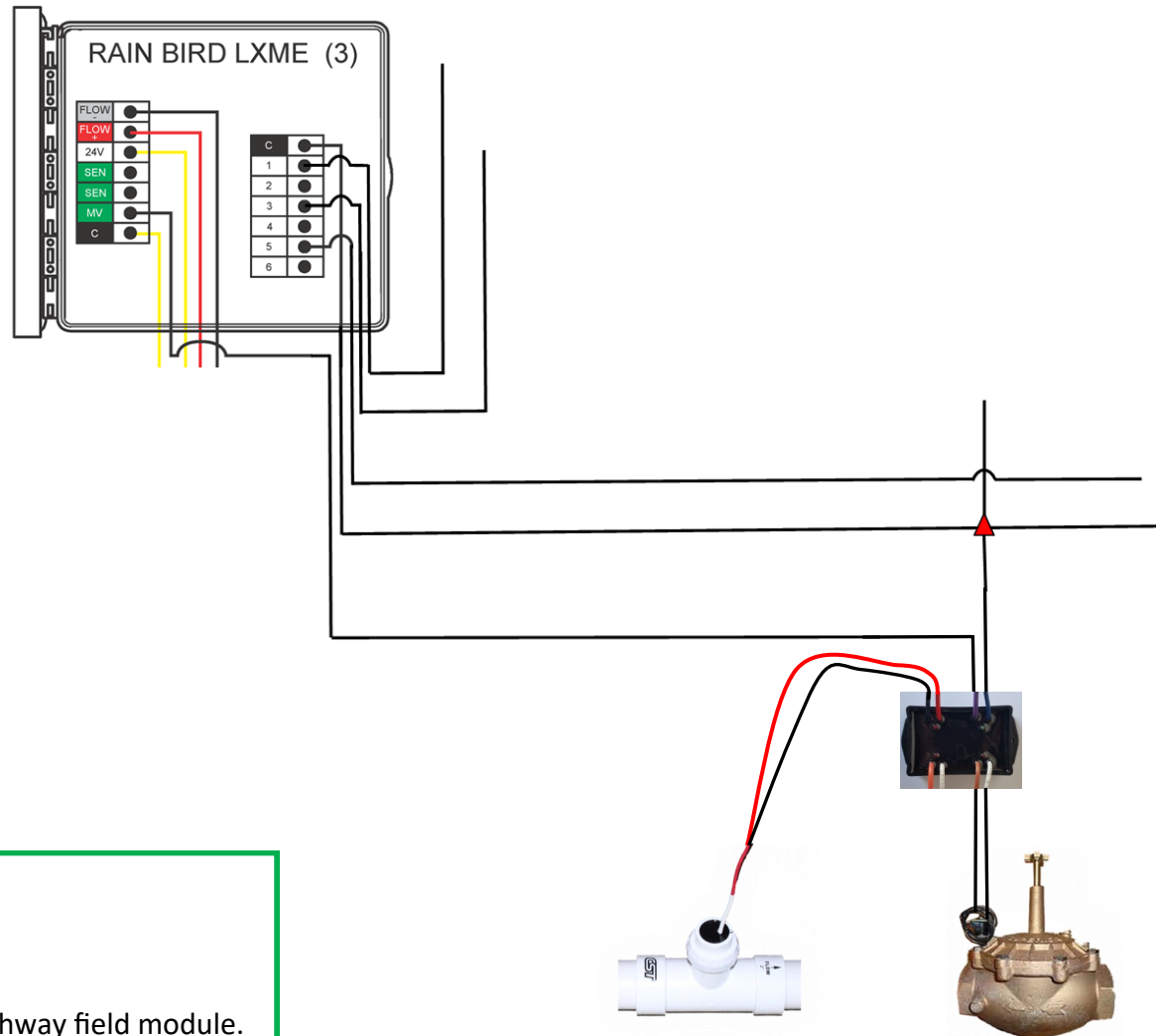

Step 2

1. Connect flow sensor red lead to red lead of Pathway field module.
2. Connect flow sensor black lead to black lead of Pathway field module.

Note: Make all splice water tight using wire nuts and grease, gel of epoxy splice kits.

Locations are shown diagrammatically. Make sure flow sensor and master valve are properly installed in the direction of flow with proper lengths of straight pipe before and after flow sensor

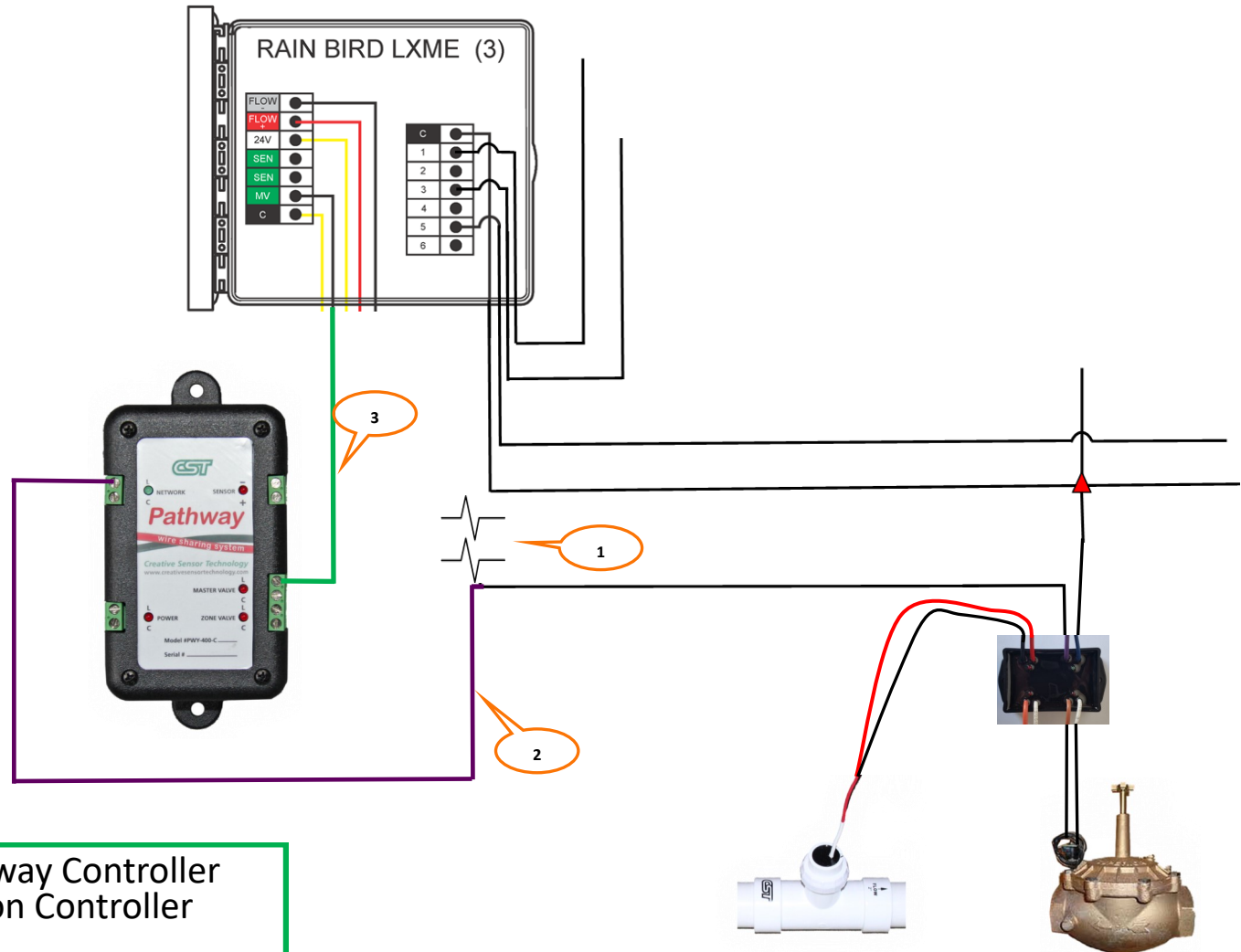

Step 3—Install the Pathway Controller Module at the Irrigation Controller

1. Break Master Valve Power wire connection to controller
2. Re-route wire from controller MV terminal to Pathway controller module MV terminal
3. Re-route MV power wire from field to Pathway controller module Network + terminal

Locations are shown diagrammatically. Make sure flow sensor and master valve are properly installed in the direction of flow with proper lengths of straight pipe before and after flow sensor

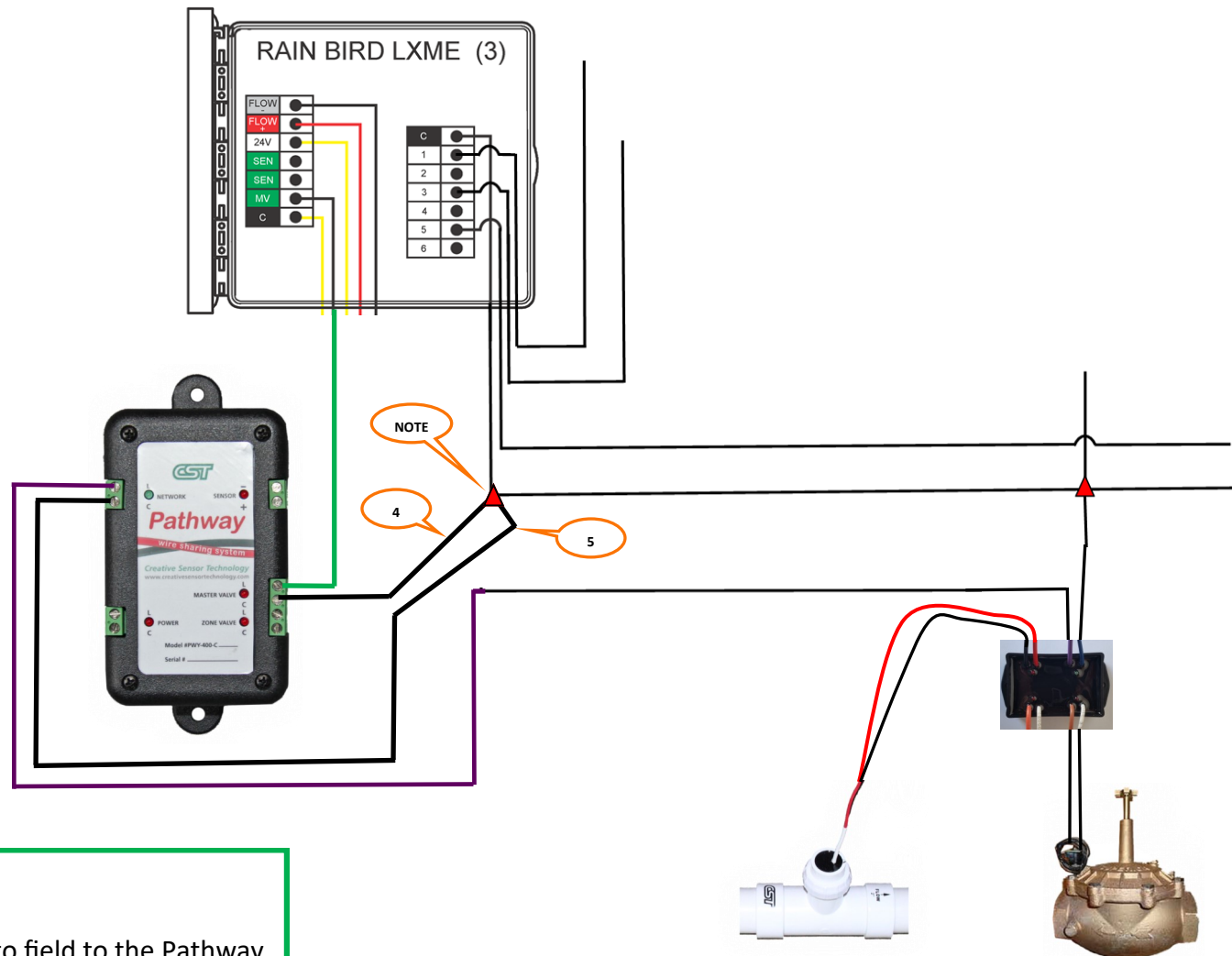

Step 4

4. Connect controller common wire to field to the Pathway controller module MV –C terminal
5. Connect controller common wire to field to the Pathway controller module Network—C terminal

Note: Use one large wire nut to make a four wire splice rather than putting two wires into a terminal.

Locations are shown diagrammatically. Make sure flow sensor and master valve are properly installed in the direction of flow with proper lengths of straight pipe before and after flow sensor

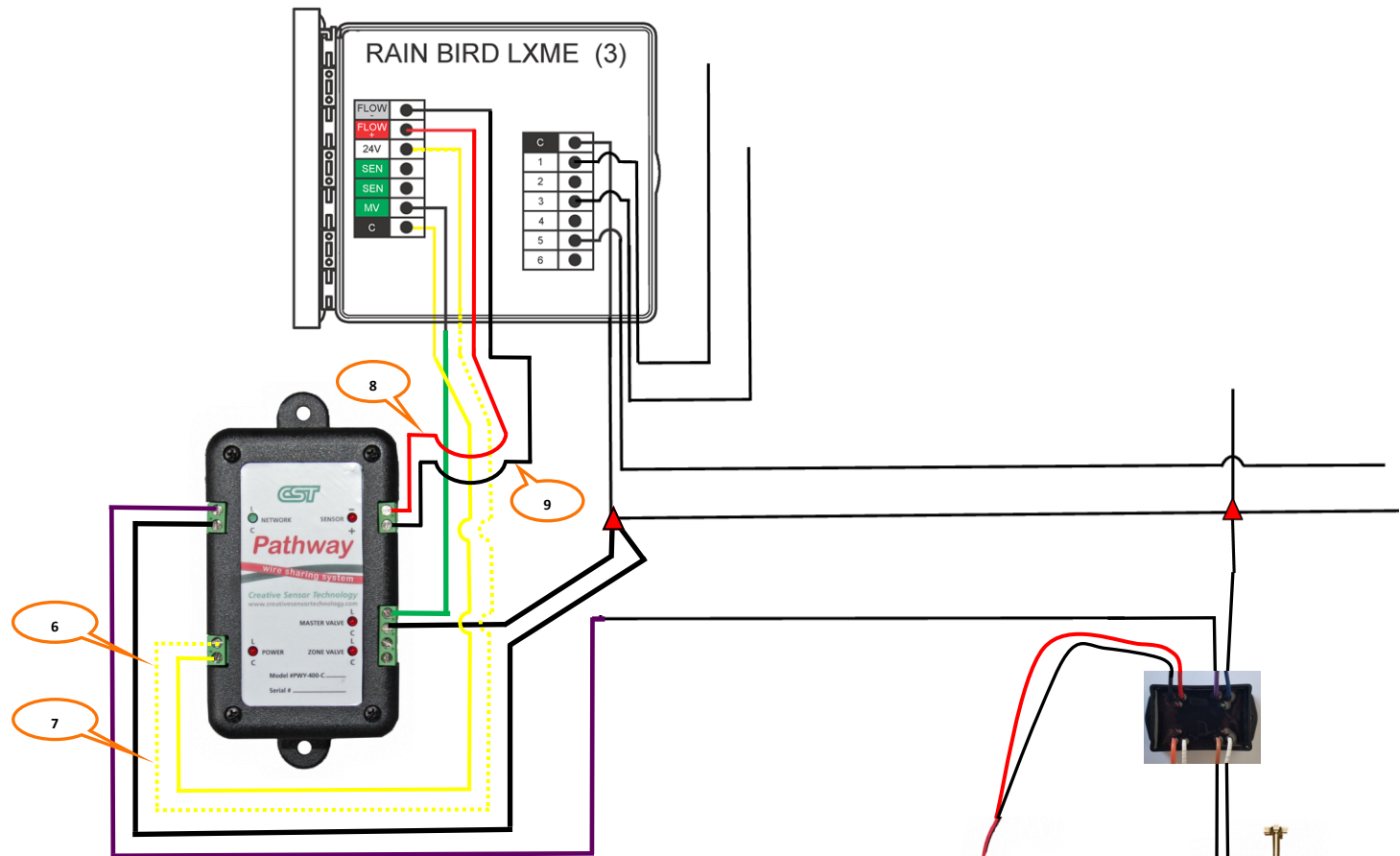

Step 5

6. Connect 24 V Power terminal on controller flow module to Power L terminal of Pathway controller module.
7. Connect Common terminal on controller flow module to Power C terminal of Pathway controller module.
8. Connect Sensor + terminal of Pathway controller module to Red Flow + terminal of controller flow module.
9. Connect Sensor - terminal of Pathway controller module to Gray Flow - terminal of controller flow module.

Finally—Power up the irrigation controller and look for all LEDs on Pathway to blink three times. Then Red Power LED and Green Network LED should blink continuously.

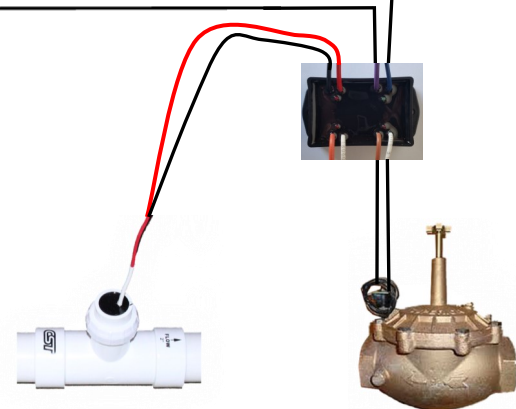

Locations are shown diagrammatically. Make sure flow sensor and master valve are properly installed in the direction of flow with proper lengths of straight pipe before and after flow sensor